

Floor Lamp | 220-240 V
3 topLED 34 W DC - 37 W AC | CRI 90

9775M

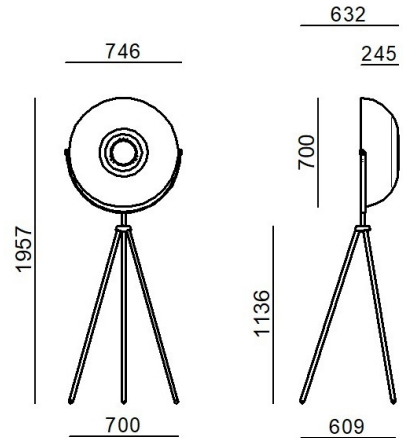

Technical data	
Type	Floor Lamp
Installation position	Floor
Installation environment	Indoor
Light Source	LED
Circuit structure	topLED
Optics	Diffused
Light emission direction	downward and upward
Nominal power	34 W DC
Total Power	37 W
Source lumens	3904 lm
Nominal input voltage	220 - 240 V AC
Input voltage range	220 - 240 V AC
Frequency	60 - 50 Hz
CCT / Tone	2700 K
Colour rendering index	90 Ra
C.C. / C.V.	AC
Safety class	1
IP	IP20
Glow wire test	850°
Direct mounting on normally flammable surfaces	Yes
CE	Yes
Driver included	Driver
Dimmable article	DALI-2 - PUSH DIM
Directional	No
Tilting	No
Walk-over	No
Drive-over	No
Cable included	Yes
Electric socket	Type F
Cable length	2 m
Resin potting	No
Type of light emission	Double emission
Net weight	9.500 Kg
Electrostatic discharge protection	No
Surge protection	No

Finishing casing	
Material	Aluminium
Colour	White
Processing	Coating
Finishing diffuser	
Colour	transparent
Processing	Laser engravings

Floor Lamp | 220-240 V | 3 topLED 34 W DC - 37 W AC | CRI 90 | Base **9775M**

Double emission floor lamp for indoor application. The super warm white LED light source with a diffused light distribution is composed of 126 topLED LEDs with CCT of 2700 K and a CRI 90; the source luminous flux is 3904 lm, with a 114.8 lm/W nominal luminous efficacy.

The device body is made of aluminium and features a white finish, processed by means of coating; the diffuser is made with a laser engravings treatment. The ingress protection degree is IP20; the total weight is of 9.500 kg.

The total absorbed power is 37 W The power supply cable is included and features a 2 m length.

The device features protection class I and can be floor-mounted.

Compliant with the EN 60598-1 standard and its specific provisions.

Energy efficiency class

This product contains 3 light sources of energy efficiency class E.

Illuminotechnical Features

Light Output Ratio (LOR)	48 %
Source lumens	3904 lm
Delivered lumens	1908 lm
Consumption	37 W
Luminaire efficacy	51 lm/W
Colour temperature	2700 K
Standard Deviation of Colour Matching	3 Step MacAdam
Colour rendering index	90 Ra
Junction temperature (lighting fixture)	80
Standard Operating Ambient Temperature	25°C

LED Life / Failure Ratio

L70 B20 C0 72500h (at Tj 115 Ta 25)

UGR

UGR axial	17.1
UGR transversal	17.3
X=4H Y=8H	S=0.25H
Reflection factor	70/50/20

OPTICAL

C90/C270 optics	50°
C0/C180 optics	57°
Light distribution symmetry	Symmetrical 2 assis

